



**ABAX
KINGFISHER**



NORDIC
PRODUCT DATA SPECIFICATION

Nordic Whiteboard Wall System

Description	
DIMENSIONS	2x Board system: 1800mmW x 1180mmH 2x Board System: 2360mmW x 1780mmH 3x Board System: 2700mmW x 1180mmH 3x Board System: 3540mmW x 1780mmH
MATERIALS	The magnetic writing surface is laid upon solid Scandinavian plywood made for architectural joinery applications.
FEATURES	Natural waxed plywood edge Rounded radius corners Magnetic dry wipe writeable surface Split batten mounting system 12.6mm thickness
WARRANTY	10 Year Warranty
LEAD TIME	49 Days
FINISH	White with Natural waxed plywood edge

Drawing

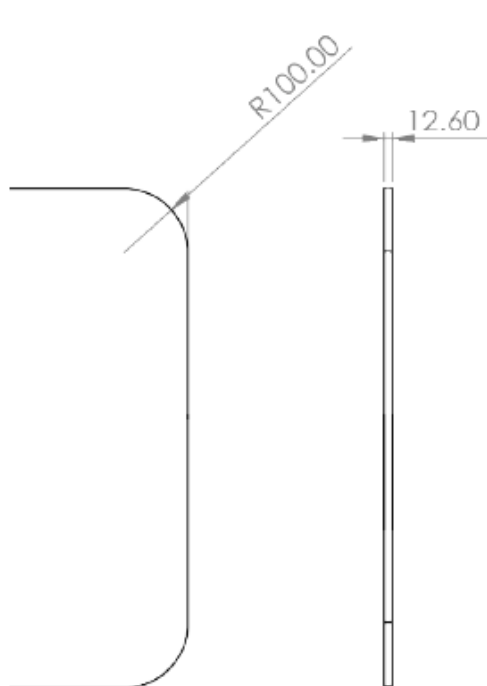

2 board system

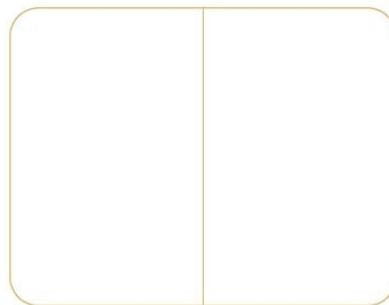

3 board System



Due to Constant innovation, products may be subject to design and specification changes without notice. Copyright © 2022